

MISTRAL OUTDOOR BANNER STANDS

OUTDOOR BANNER STANDS

OUTDOOR BANNER STANDS



Moulded plastic base

No loose parts

Quick and easy assembly

plex
DISPLAY
outdoor banner stands

MISTRAL

OUTDOOR BANNER

HIGHLY DURABLE AND ROBUST BANNER STAND SPECIFICALLY DESIGNED FOR OUTDOOR USE. **QUICK AND EASY ASSEMBLY** WITHOUT THE NEED FOR ANY TOOLS. MOULDED PLASTIC BASE CAN BE FILLED WITH WATER OR SAND TO GIVE ADDED STABILITY.

FEATURES

- Highly durable, single sided banner stand, specifically designed for outdoor usage
- No loose parts
- Quick and easy assembly without the need for any tools
- Moulded base can be filled with water or sand for extra stability
- 1570 x 460mm graphic panel size
- Comes complete with carry bag
- High impact sales tool, ideal for use in any outdoor corporate or retail environment

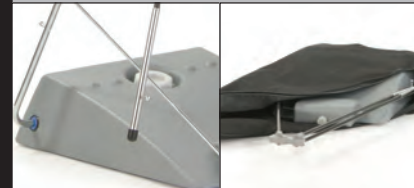

plex
DISPLAY
outdoor banner stands

DURABLE AND ROBUST

STAND

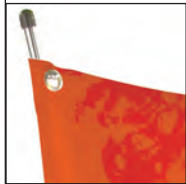

OUTDOOR BANNER STANDS

WATER FILLED BASES | HIGH IMPACT | VERSATILE | 2 YEAR WARRANTY

SPECIFICATIONS

GRAPHIC SIZE

1570 (H) X 460 (W)mm

GRAPHIC EYELETS

Eyilet Position

Length (between centres) = 1525mm

Width (between centres) = 415mm

Minimum eyelet size

Minimum Internal Diameter = 10mm

SYSTEM SIZES

Assembled

1820 (H) x 500 (W) x 600 (D)mm

Boxed sizes

1100 (L) x 570 (W) x 140 (D)mm

BOXED WEIGHT

4.3kg

MOULDED BASE CAPACITY

12 litres

COMPONENT LIST

1 x unassembled Mistral outdoor

banner

1 x carry bag

MISTRAL - OUTDOOR BANNER STAND ASSEMBLY INSTRUCTIONS

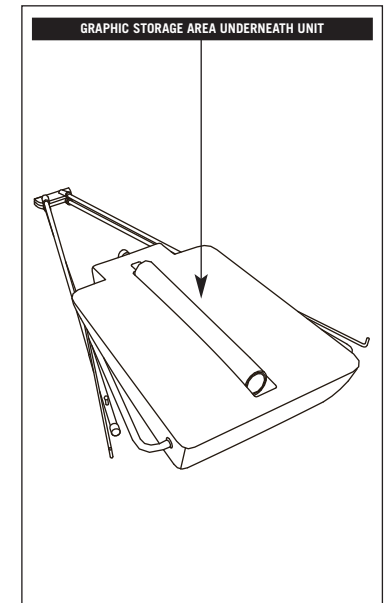
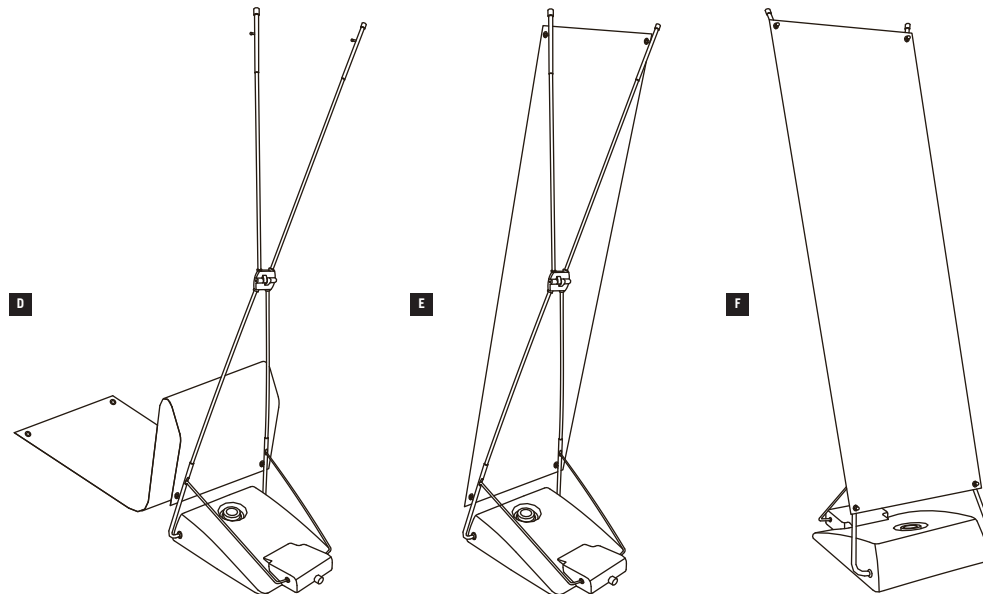
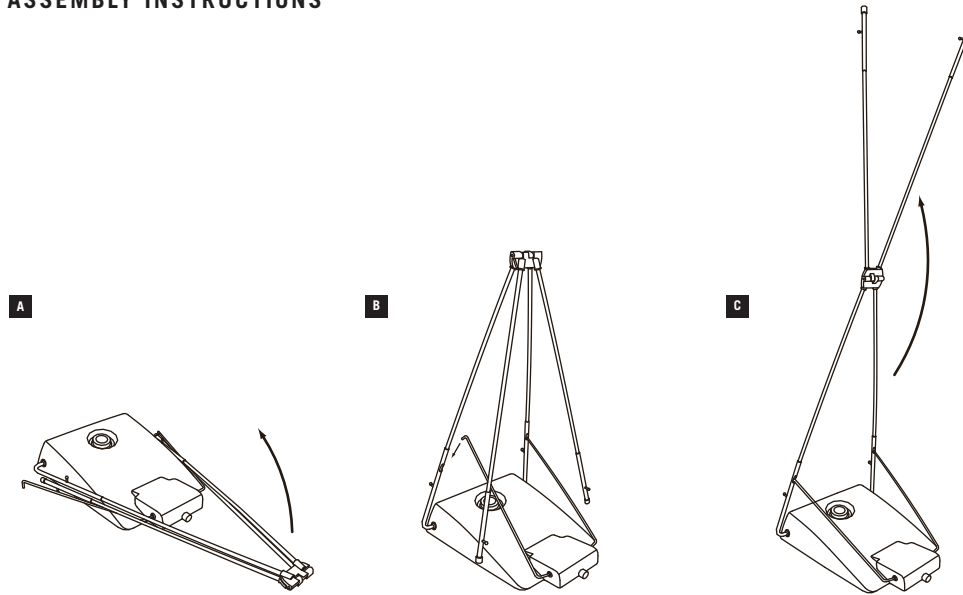

plex
DISPLAY

Issue 3 - June 2007

• Moulded base can be filled with either water or sand for extra stability. If the base is filled with water ensure that precautions are taken to stop the water freezing as it may cause damage to the base.